

SERIE

INGRESSO BRILLET

Design moderno e innovativo caratterizzano il sistema ingresso Brillet. Dotato di tripla guarnizione, due di battuta e una pinna morbida centrale, garantiscono un ottimo isolamento termico. Il rinforzo Fortex nel telaio ed le ante con rinforzo in acciaio di adeguate dimensioni garantiscono robustezza e sicurezza.



Robustezza e resistenza



Isolamento termico ottimizzato



Garanzia e qualità certificata

TRASMITTANZA TERMICA

NODO (Uf)	1,35 W/m ² K
VETRO (Ug)	1,10 W/m ² K
COMPLESSIVO (Uw)	1,26 W/m ² K

Uw fino a **0,86 W/m² K** (con adeguato vetraggio)

Uw: valori termici dei singoli componenti dell'infisso (telaio e vetrazione)

CARATTERISTICHE TECNICHE

- Rinforzi in acciaio zincato in massa di spessore adeguato e di notevoli dimensioni
- Adatto al montaggio di vetri tripli fino a 60 mm di spessore
- Ferramenta Roto Door di sicurezza
- Ampia scelta di serrature standard, chiusura multipla, elettrica
- Cerniera a vista con regolazione tridimensionale e di grande portata
- Vasta gamma di finiture
- Prodotto 100% Made in Italy



VERIFICA	RISULTATO DELLA VERIFICA	OSSERVAZIONI
Verifica di idoneità in conformità a RAL-GZ-716-1	Permeabilità all'aria conforme a DIN EN 12207: classe 4 (1 anta) Permeabilità all'aria conforme a DIN EN 12207: classe 4 (2 ante) Resistenza alla pioggia battente conforme a DIN EN 12208: classe 7 (1 anta) Resistenza alla pioggia battente conforme a DIN EN 12208: classe 5A (2 ante) Resistenza al carico del vento conforme a DIN EN 12210: classe C1 (1 anta) Resistenza al carico del vento conforme a DIN EN 12210: classe C2/B2 (2 ante)	Verifica effettuata su ingresso ad apertura interna

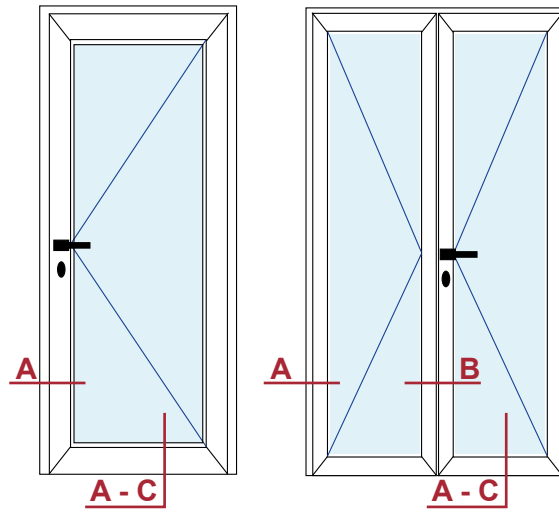

SEZIONE A-C

SEZIONE A

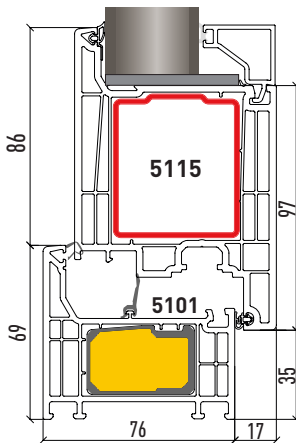

SEZIONE A-C

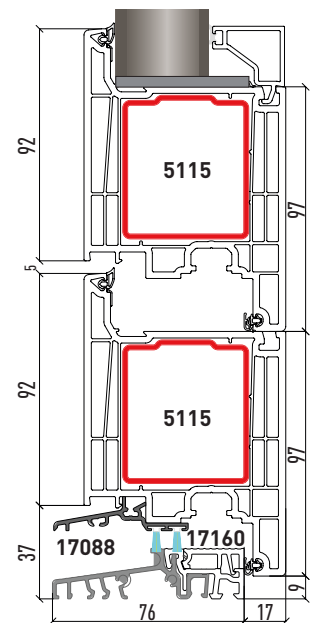
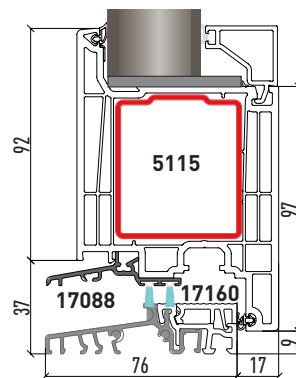

SEZIONE B

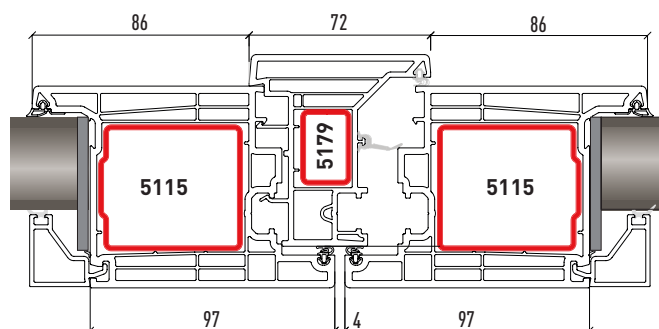

COLORI MASSA



Bianco 3

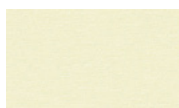

Avorio 096

RIVESTIMENTI TIPO A



Ciliegio 110

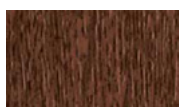

Noce 154



**Bianco classico
100**



Crema 96



**Cedro sbiancato
694**



Grigio Cedro 143



Grigio 004



Verde scuro 006



**Grigio Antracite
lucido 048**

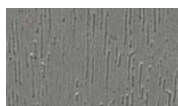

**Grigio Quarzo
068**



**Grigio Antracite
072**



Blu Acciaio 079



Winchester 109

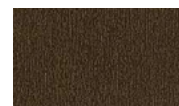

**Bronzo scuro
138**

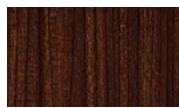

Macore 144



**Alluminio Grigio
184**

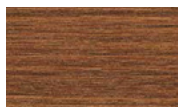

Douglas 402

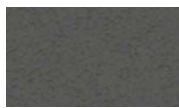

**Moondance
liscio 628**



Grigio liscio 651

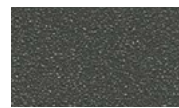

Alux DB703 653



**Noce Sorrento
Balsamico 663**



**Grigio Basalto
667**



**Grigio Antracite
Stylo 686**



**Nero Grafite
Stylo 690**



**Grigio Chiaro
907**



**Alluminio liscio
911**



**Alluminio Bianco
925**

RIVESTIMENTI TIPO B



**Rosso scuro
027**



**Nero Grafite
Matt 043**

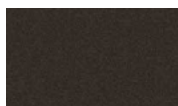

**Grigio Ombra
Matt 044**



**Woodec Turner
Oak Matt 047**



**Grigio Antracite
Matt 103**

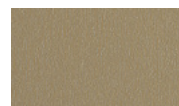

**Bronzo
spazzolato 119**



**Verde Muschio
134**

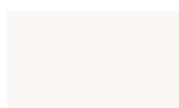

Bianco Matt 358